

## LUXURY RIGID CORE SPC FLOORING

Inspect ALL materials carefully BEFORE installation. Warranties DO NOT cover materials with visible defects once they are installed.

It is the responsibility of the installer/owner to determine if the job site subfloor and job site conditions are environmentally and structurally acceptable for Rigid Core floor installation. The flooring manufacturer declines any responsibility for floor failure resulting from or connected with subfloor, subsurface, job site damage or deficiencies after hardwood flooring has been installed.

### CHECKLIST:

- Flooring should only be installed in temperature-controlled environments. It is necessary to maintain a constant temperature 48 Hours before, during and after the installation.
- Store the packages in the future room climate and open package after package
- This floor will be floating installed, i.e. always keep a minimum 1/4" distance to all walls and vertical obstructions. Do not install cabinets on top of this product.
- Check your subfloor, it must be dry (measure always!), clean, firm, and flat.
- Measure the room and decide installation direction. Note the limitations as per below
- Transition are required only if installing in a room or area that is larger than 100 lineal ft. in any direction.
- Radiant Heat – see IN-FLOOR RADIANT HEAT and requirements below.
- Check your floor continuously during the installation. Defective boards that are installed are not covered by warranty
- To preserve your floor, clean and maintain your floor correctly.

### Tools for Installation:

Utility Knife, Straight Edge, Measuring Tape, 1/4" Spacers, Pencils, Eye Protection, Soft-Faced Rubber Mallet, Broom, Felt Pads, Tapping Block, Pull Bar, Level

*Optional:* Carpenter's Square, Jig Saw, Table Saw, Miter Saw, Circular Saw, Hole Saw, Moisture Meter (wood, concrete, or both). Power tools can be dangerous, operate in strict accordance with manufacturer's operating instructions and safety precautions.

### GENERAL REQUIREMENTS (ALL SUBFLOORS):

- Must be flat to within 3/16" in a 10ft radius; no bumps or low spots. Subfloors should not slope more than 1" per 6ft.
- Must be clean: no construction debris, soil, mud or any other objects on or adhering to the floor. If necessary, scrape and sweep away before the installation; no protrusions of nails, debris, or metals should remain.
- Must be free from moisture-related conditions that can damage the installed flooring.
- Be structurally sound without deflection.
- DO NOT install material over wood subfloors that lay directly on concrete or over sleeper construction.

### Important Information:

- You should allow for 5%-10% more flooring than square footage to account for cuttings and waste
- When installing the subfloor flatness tolerances should be no more than 3/16" in 10 ft. Radius and there should be no abrupt height differences. High spots should be sanded or ground down and low areas should be filled.
- Over concrete subfloors we recommend using 6 mil polyfilm moisture barrier.
- If excessive moisture, over 85% RH, is present or if slab moisture cannot be verified, the use of a 6 mil polyfilm moisture barrier is required. The moisture barrier should be overlapped six inches and taped at the seams.
- Rigid Flooring includes a pre-attached sound reduction pad therefore no underlayment is required.

## Important Information (cont'd)

- Do not use any additional sound suppression underlayment or padding, as doing so will void the Limited Warranty.
- Transitions are required only if installing in a room or area that is larger than 100 lineal ft. in any direction.
- Irregularities in concrete subfloor should be filled and leveled using a cementitious patching or leveling compound (Follow Subfloor Flatness Tolerances).
- **Installing on Stairs or vertical surfaces such as walls will void your Warranty**
- When installation over existing ceramic tile floors it is not necessary to fill grout lines (Follow Subfloor Flatness Tolerances).
- **Any glue down installation will void the Warranty**
- Subfloor RH/MVER Recommendations 85% Relative Humidity/ 8 lbs. MVER (Moisture Vapor Emission Rating) Radiant Heat Approved
- Allow for a 1/4" expansion gap around perimeters walls & heavy fixed objects such as cabinetry, pipes, or baths.
- "Waterproof" - Structural integrity of Rigid Core flooring will not degrade due to contact with moisture/water.

## PRE-INSTALLATION BASICS:

If the Rigid Core Flooring is subject to extreme hot or cold temperatures prior to installation, allow the product to acclimate 48 hours or to room temperature (between 55° - 85°F - 13°- 29°C or average temp. of 70 degrees (21.1°C).

Post installation Environmental Conditions should be maintained at 0°F (-18°C) - 140°F (60°C)

Product should be stored (flat) in a dry area away from direct sunlight. Do not leave next to heating or cooling ducts. All work involving water must be completed well in advance of the installation of Rigid Core Flooring. Do not store flooring in uncontrolled environmental conditions. For example, garages and exterior patios are not acceptable areas to store flooring. Flooring stored on a concrete slab should be elevated at least 4" to allow air circulation under cartons. Ensure that all trades have been completed, including; drywall, plasterwork, plumbing, painting, etc.

**Shade Variations:** Randomly pull planks from three or more different cartons to ensure good color and shade mixture. Carefully inspect each plank for visual defects prior to installation. Do not install damaged planks.

## JOB SITE EVALUATION:

Prior to installation, the homeowner or installer must ensure that job site conditions (including subfloor/substrate, ambient temperature and relative humidity) will not negatively affect the floor. The manufacturer is not responsible for damages associated with improper installation or poor site conditions.

### Moisture

Test all concrete subfloors for moisture content and document the results. Visual checks are not reliable. Moisture must still be checked even though vinyl plank flooring is waterproof in order to protect surrounding structure.

### Crawl Spaces

Concrete slab or ground must be dry. Ensure that crawl spaces have open vents year-round to ensure proper air circulation and prevent moisture build-up. The ground in the crawl spaces must be completely covered using 6 mil polyethylene. Crawl space clearance between the earth and underside of joists should be no less than 18" and the perimeter vent area should be equal to 1.5% of the total square footage of the crawl space or as mandated by code.

## APPROVED SUBFLOORS

Concrete, Plywood, OSB, Particleboard, Chipboard, Hardwood (Solid, Engineered, Parquet) on plywood Subfloor, Tile (Ceramic, Terrazzo, Stone, Asbestos, Peel and Stick), Fully Adhered Non-Cushion Sheet Vinyl, Metal, VCT.

## NON-APPROVED SUBFLOORS

Carpeting/Carpet Pad, Cushioned Vinyl Flooring, Floating Floors, Laminate, Sleeper Substrates, Rubber Perimeter Bonded or Cushioned-Back Vinyl Flooring, Hardwood (Solid, Engineered, Parquet) on Concrete  
Remove the floors noted and remove old adhesive before installing Rigid Core flooring.

All subfloor requirements noted below must be met prior to installation.

#### **GENERAL REQUIREMENTS (ALL SUBFLOORS):**

- Must be flat to within 3/16" in a 10ft. radius; no bumps or low spots. Subfloors should not slope more than 1" per 6ft.
- Must be clean: no construction debris, soil, mud or any other objects on or adhering to the floor; if necessary, scrape and sweep away before the installation; no protrusions of nails, debris, or metals should remain.
- Must be free from moisture-related conditions that can damage the installed flooring.
- Be structurally sound without deflection.

#### **CONCRETE SUBFLOORS**

- High spots can be removed by grinding; depressions can be filled with patching compound formulated for use in floor installation.
- Cure for at least 90 days (applies to newly-laid concrete slabs).
- Can be either sealed or unsealed.
- Between 7 and 9 alkalinity when performing pH test (ASTM F710).
- Moisture content should meet one of the following criteria:
  - 4% max. when tested using Tramex Concrete Moisture Encounter.
  - Less than 8 pounds per 1000 sq. ft. per 24 hours MVER (Moisture Vapor Emission Rating) when using Calcium Chloride test (ASTM F1869).
  - 85% max. when performing Relative Humidity Testing (ASTM F2170).

#### **WOOD (PLYWOOD, OSB, PARTICLEBOARD, CHIPBOARD, SOLID HARDWOOD, LUAN) SUBFLOORS**

- Wood subfloors must be A.P.A approved with a minimum grade of "BB" or "CC". For reference, A.P.A. is the acronym for an organization originally known as the "American Plywood Association", and that is now known as "The Engineered Wood Association".
- Perform moisture tests using a reliable moisture meter in multiple locations. Moisture readings should never exceed 14% for plywood, OSB, particleboard, chipboard, and solid hardwood subfloors. If moisture readings exceed 14%, it should be corrected at the job site before installing vinyl plank flooring.

#### **TILE, TERRAZZO, ASBESTOS TILE, RESILIENT TILE, NON- CUSHION SHEET VINYL, AND METAL SUBFLOORS**

- Existing floors must be firmly attached to the structural floor.
- Fill in grout lines larger than 1/4" on ceramic tiles, terrazzo, quarry tiles, and similar floors with a cementitious leveling and patching compound.
- Install over one layer of vinyl only.

#### **IN-FLOOR RADIANT HEAT:**

This product can be installed over radiant heat concrete subfloors. Consult with the radiant heat system manufacturer to ensure that the system is compatible with vinyl flooring.

- Electric and hydro systems are acceptable.
- In-floor radiant components must be a minimum of 1/2" below flooring.
- Floor surface temperature should never exceed **85°F**.
- Heating system should be operational for at least two weeks prior to installation to calibrate temperature settings.
- **Flooring cannot be laid directly over radiant heating mats.**

**CAUTION:** If you contemplate the removal of a resilient floor covering structure that contains (or is presumed to contain) asbestos, you must review and comply with all applicable regulations. Do not sand, dry sweep, dry scrape, drill, saw, bead blast, or mechanically chip or pulverize existing resilient flooring, backing, lining felt, asphalt "cut- back" adhesive, or other adhesive. These products may contain asbestos fibers and/or crystalline silica. Avoid creating dust. Inhalation of such dust is a cancer and respiratory tract hazard. Smoking by individuals exposed to asbestos fibers greatly increases the risk of bodily harm. Unless positively certain that the product is a non-asbestos containing material, you must presume it contains asbestos. See "Recommended Work Practices for Removal of Resilient Floor Coverings" ([rfci.com](http://rfci.com)) for detailed information and instructions on removing all resilient covering structures.

## HELPFUL POINTERS & PREPARING FOR INSTALLATION:

- Work area should be well lit. Proper visibility ensures that color is consistent and that visually defective planks are detected and removed. *Subfloor must be clean and free of debris.*
- Undercut doorjambs and casings using a handsaw laid flat on a piece of scrap flooring. Never undercut metal door casings.
- Carefully remove the existing base, shoe molding or thresholds. They can be reused to cover the ¼" expansion gap around the edge of the room.
- Must be flat to within 3/16" in a 10ft radius; no bumps or low spots. Subfloors should not slope more than 1" per 6ft.
- The minimum length of the first and last plank is 8". If the last plank will be less than 8", adjust the length of the first plank. The remainder of the last plank can be used as a starter plank on the following rows.
- The minimum end-joint stagger is 8". Keeping this in mind, vary the distances from end joints row-to-row for a more random and realistic installation.
- **Shade Variations:** Randomly pull planks from three or more different cartons to ensure good color and shade mixture. Carefully inspect each plank for visual defects prior to installation. Do not install damaged planks.

## AVAILABLE MOLDINGS:

Select moldings and transitions are available at [www.versatrim.com](http://www.versatrim.com)

**NOTE:** 12" Tiles **ONLY** must be installed in a brick pattern, where the seams are staggered



## INSTALLATION:

Inspect each plank. Blend planks from several cartons at the same time to ensure good color and shade mixture throughout the installation.

1. Set spacers to allow a minimum gap of ¼" around the perimeter of the subfloor for movement or product expansion. Do not remove the spacers until the installation is complete. The expansion gaps should be covered by molding. See diagram 4.
2. Measure the length of the room in inches. Divide it by the width of the planks that are to be installed. If the resulting number is less than the to be installed plank width, you will need to cut your first-row planks accordingly to avoid having planks that are less than the plank width on the opposite end of the room.

*Note: To cut a plank, simply measure and mark the plank. Then, use a straight edge and utility knife to score and snap. You may also need to back-cut the under pad on the bottom of the plank. If you have difficulty using this method, you can use a jig saw, circular saw or miter saw.*

3. Begin installation of flooring from a corner of the room and working from left to right. Install spacers between the plank and the wall at the end and edges where the plank and wall come together. See Diagrams 5 & 6.
4. Begin the first row with a whole plank. First saw off the tongue on both the long and short sides of the first plank. See diagram 3.
5. Lock short end of plank 2 by inserting tongue into groove at an angle. Then drop into place. Continue this step to the end of the row.
6. The end joints of the planks in the first row are assembled by inserting the tongue side into the groove side of the previous plank at a low 20-30° degree angle. Gradually lower the plank down flat, applying pressure inward and downward clicking and locking the end of the new plank into the end of the existing plank until the end joint closes. Ensuring that the planks are perfectly aligned. Install remaining full planks in the first row.
7. Cut the last piece of the row to fit and allow for the ¼" expansion gap (if you have not already done so). Install as shown. See Diagram 7.
8. Use a tapping block and soft faced rubber mallet to close any gaps between the planks.

## INSTALLING SECOND & REMAINING ROWS:

9. Cut the first plank of the second row to two-thirds its length or make sure there will be at least an 8" stagger between end joints. Angle the long tongue edge of the plank into the long groove edge of the first plank at 20°-30°. Drop and lock the end joints together. Make sure there are no gaps, **do not** tap the short end into place if the long joint is not properly engaged, as doing so can cause damage to the tongue and groove.

*Note: When starting a new row, you can use the cut piece from the previous row, as long as it is more than 8" and the stagger between seams still is greater than 8". See Diagram 8.*

10. When installing the first plank of the second row, remember to place a ¼" inch spacer between the wall and the short side of the plank. Insert the long side tongue into the groove side of the plank in the first row at a low angle and lower flat to the substrate. Shift the plank down toward the end seam and slightly lift the previous plank in order to engage the end joints together.
11. Install the second plank of the second row. Position the long side of the second plank with the tongue side of the existing plank overlapping the groove of the planks in the previous row approximately 1/8" inch. Then, angle the end joint into the previous plank. Angle the plank down and gently push in until the plank locks into the previous row (Refer to Figure 10). Continue installing remaining planks in the second row.

**MAKE SURE THAT THE FIRST TWO ROWS ARE STRAIGHT AND SQUARE, OR THIS WILL AFFECT THE ENTIRE INSTALLATION**

12. Continue working from left to right, row by row, making sure to install the planks with the long side seam first, then slide back to drop the end joint into place. Tap the ends to ensure a tight fit.

13. Install remaining rows, one row after the other, and maintain the required 8" stagger throughout the install. Tap and square each plank as in step 12-14.

#### **INSTALLING THE LAST ROW:**

14. Most often the entire length of the last row will need to be cut so that it is narrow enough to fit the remaining space. Cut the first plank of the last row to length (if necessary to follow stagger pattern). Place directly on top of the previously installed row. Then, take another plank and place it against the wall on top of the plank to be cut for width. Mark the plank (length-wise), cut to size. Remember to allow for the 1/4" expansion gap against fixed objects. See diagram 15.

Install the plank with the cut side always facing the wall. Continue to cut and install remainder of the planks in the last row. Use of a pull bar and rubber mallet to lock the joints together in the last row may be necessary. Always use a pull bar on the cut edge of the plank. Factory edges can be damaged if the pull bar is used directly against them.

**Note:** *Be sure to leave a minimum of 1/4" expansion space around all fixed objects, cabinetry, and metal door jambs.*

Installation (cont'd)

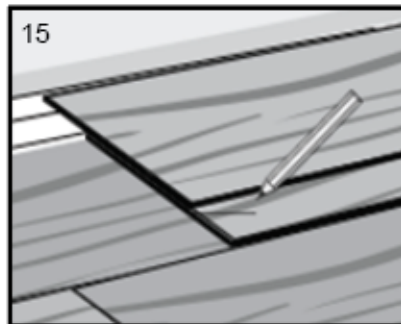
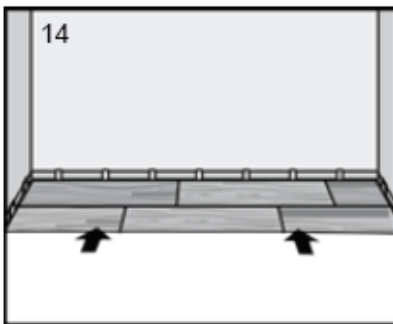
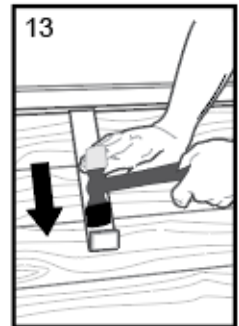
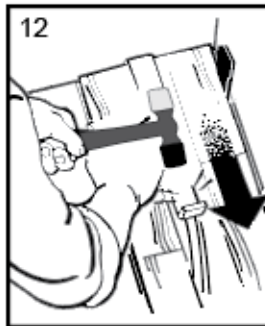
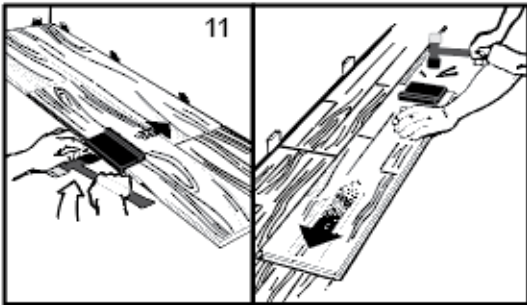
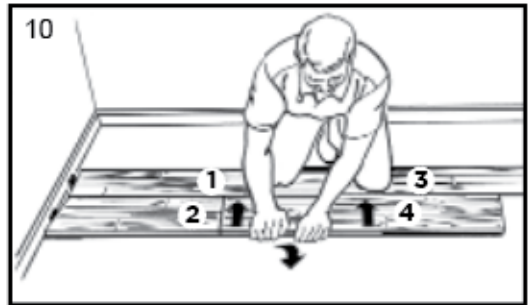
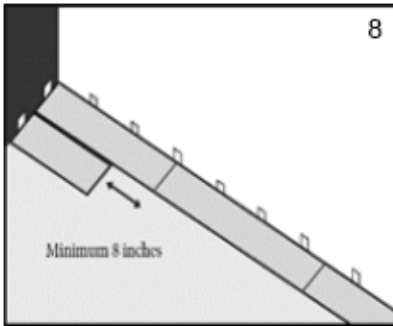
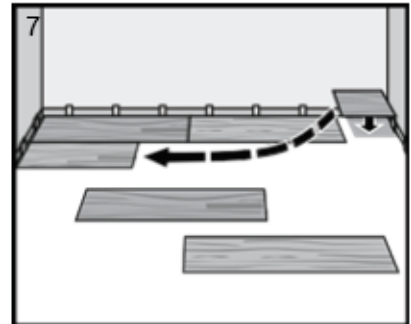
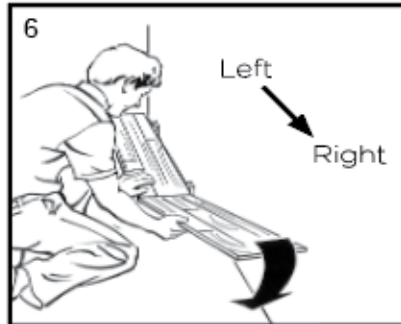
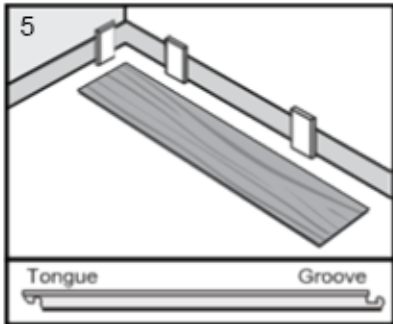
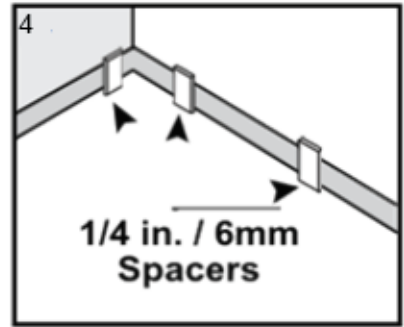
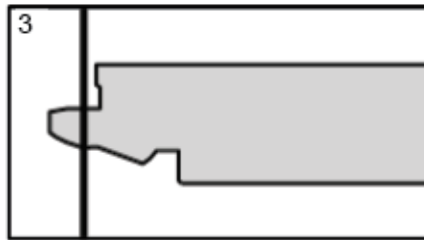
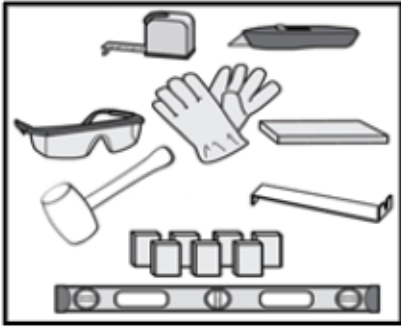

## AFTER THE INSTALLATION:

Remove spacers. Cover expansion spaces with quarter round or other trim.

Fill any expansion spaces around potentially wet areas (such as refrigerators, tubs, etc.) with premium, waterproof 100% silicone caulk.

A room or area that is larger than 100 lineal feet in any direction, so that the floor is separated into sections that are no larger than 100ft. x 100ft. per section.

Save and protect any leftover planks. Do not discard, they can be used for replacement in the event you need to replace a plank in the future.

## CARE & MAINTENANCE - DAILY MAINTENANCE:

- Vacuum your floors instead of sweeping
- Vacuum your floors as part of a regular weekly routine, as well as after any event that has left dirt behind. Gravel and dirt of any kind have the potential to damage the floor if not removed properly and promptly. Vacuuming, with a floor attachment rather than a beater bar, is preferred to sweeping because it not only addresses the surface of the floor but pulls particulates from between the planks.
- Never use a rotating brush, floor scrubbers, jet mops, buffers or similar products.
- To minimize the amount of dirt and grime on your floors, place mats outside and inside of all exterior doors.
- The occasional spill should be cleaned up immediately with a dry cloth. A damp cloth may be used for a stickier mess, but the area should be dried afterwards.
- For lightly soiled areas, clean with distilled water.
- When the cleaning cloth/mop becomes soiled, rinse with clear water and air dry or replace it with a clean one. Following up with a clean, dry cloth will remove residual streak-marks and spots.
- Promptly remove any standing water, pet urine or other liquids.
- If using a store-bought floor care **cleaning** product, follow manufactures guidelines. Test the product in an inconspicuous place (e.g. closet, corner, or scrap pieces) for potential, adverse side effects. For a list of NONAPPROVED products see below.

---

## DO NOT:

- **DO NOT** use a steam cleaner.
- **DO NOT** vacuum with a beater bar or power rotary brush head.
- **DO NOT** use any cleaning agents containing wax, oil or polish. Leftover residue will form a dull film.
- **DO NOT** use steel wool or scouring pad, as they will scratch the floor.
- **DO NOT** use any dust cleaners, as they may cause your floor to become slick or damage the finish

---

## PREVENTATIVE MAINTENANCE:

- Protect your floor when using a dolly to move furniture or appliances. Protective sheets and/or plywood may be needed. Never slide or roll heavy furniture or appliances across the floor.
- Use flat floor protectors (felt) on all furniture legs. Periodically clean protectors to remove grit that may become embedded and cause scratching.
- Minimize abrasive material and dirt by placing mats on both sides of exterior doors and by using area rugs in high-traffic areas.
- Use NON-RUBBER backed mats that are labeled "colorfast" by the manufacturer. Non-staining, vinyl-backed mats or woven rugs should be used at all entrances to prevent dirt and grit from being tracked onto your floor.
- Use protective mats beneath rolling chairs and keep furniture casters clean. We recommend the use of a hard surface (non-studded), non-rubber chair mat to protect your floor from office chairs with casters. Light, rolling furniture should be outfitted with broad-surface, non-staining barrel-type casters that have been engineered for hard surface floors. Such barrel-type casters should be a minimum of 1" wide and at least 2" in diameter.
- Spike or stiletto heels can cause damage to your floor.
- Also remember to keep your pet's nails trimmed or filed